

# Pogo Hop

INFLATION  
INSTRUCTIONS



# Assembly Tips / Conseils d'Assemblage

(Adult Assembly Required / Assemblage Adulte Requis)

## STEP 1: Partially Inflate Pogo Hop

Using a manual air pump, insert the inflation needle into the valve opening. Inflate the Pogo-hop ball until it just starts to become round, then remove needle from valve.

## ÉTAPE 1: Gonfler partiellement Pogo Hop

À l'aide d'une pompe à air manuelle, insérez l'aiguille de gonflage dans l'ouverture de la valve. Gonflez la balle Pogo-hop jusqu'à ce qu'elle commence juste à devenir ronde, puis retirez l'aiguille de la valve.

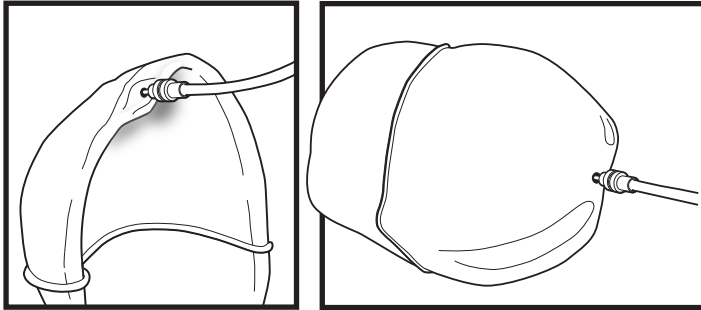

## STEP 2: Insert Pogo-Hop Ball in Platform

With valve side down, insert the Pogo-Hop ball into the hole in the platform. The mid-rim on the ball goes on the bottom and presses against the bottom of the platform.

## ÉTAPE 2: Insérer la balle Pogo-Hop dans la plate-forme

With valve side down, insert the Pogo-Hop ball into the hole in the platform. The mid-rim on the ball goes on the bottom and presses against the bottom of the platform.

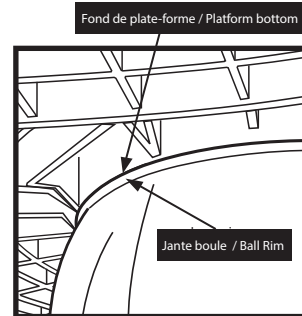

## STEP 3: Cut Out Sizer and Finish Inflating!!

Cut along the dotted line below. Re-insert the inflation needle and continue inflating the Pogo-Hop ball until the top of it fits into the curved outline.

## ÉTAPE 3: Découpez le calibre et terminez le gonflage !!

Coupez le long de la ligne pointillée ci-dessous. Réinsérez l'aiguille de gonflage et continuez gonfler la balle Pogo-Hop jusqu'à ce que le haut s'insère dans le contour incurvé..

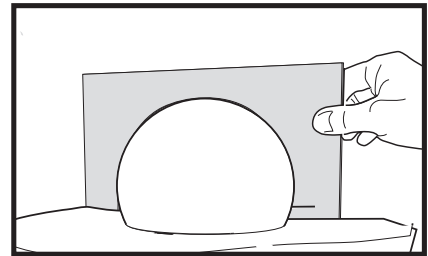

 **Hedstrom**<sup>®</sup>  
Ashland, Ohio  
1-800-765-9665  
RMN 069647  
4-23-2021